



PEARSON NEW INTERNATIONAL EDITION

**Automotive Engines:  
Theory and Servicing**  
James D. Halderman  
Seventh Edition

# Pearson New International Edition

---

Automotive Engines:  
Theory and Servicing  
James D. Halderman  
Seventh Edition

## REVIEW QUESTIONS

1. What types of coolant are used in vehicles?
2. Why is a 50/50 mixture of antifreeze and water commonly used as a coolant?
3. What are the differences among IAT, OAT, HOAT, and PHOAT coolants?
4. What are some of the heavy metals that can be present in used coolant?
5. What is the difference between galvanic activity and electrolysis?

## CHAPTER QUIZ

1. Coolant is water and \_\_\_\_\_.
  - a. Methanol
  - b. Glycerin
  - c. Kerosene
  - d. Ethylene glycol
2. As the percentage of antifreeze in the coolant increases, \_\_\_\_\_.
  - a. The freeze point decreases (up to a point)
  - b. The boiling point decreases
  - c. The heat transfer increases
  - d. All of the above
3. Adding a chemical to make ethylene glycol coolant bitter to the taste is called \_\_\_\_\_.
  - a. Passivation
  - b. Embittered
  - c. Refractometer
  - d. Electrolysis
4. Asian red coolant is what type?
  - a. IAT
  - b. OAT
  - c. HOAT
  - d. PHOAT
5. DEX-COOL is what type of coolant?
  - a. IAT
  - b. OAT
  - c. HOAT
  - d. PHOAT
6. PHOAT coolant is what color?
  - a. Dark green
  - b. Red
  - c. Orange
  - d. Blue
7. DEX-COOL is \_\_\_\_\_.
  - a. Propylene glycol
  - b. Ethylene glycol
  - c. Is silicate and phosphate free
  - d. Both b and c
8. Two technicians are discussing testing coolant for proper pH. Technician A says that coolant has a pH above 7 when new and becomes lower with use in an engine. Technician B says that OAT and HOAT coolants have a lower pH when new compared to the old green IAT coolant. Which technician is correct?
  - a. Technician A only
  - b. Technician B only
  - c. Both Technicians A and B
  - d. Neither Technician A nor B
9. Reusing old coolant is generally not approved by vehicle manufacturers *except* \_\_\_\_\_.
  - a. General Motors
  - b. Ford
  - c. Chrysler
  - d. Mercedes
10. A voltmeter was used to check the coolant and a reading of 0.2 volt with the engine off was measured. A reading of 0.8 volt was measured with the engine running and all electrical accessories turned on. Technician A says that the coolant should be flushed to solve the galvanic activity. Technician B says that the ground wires and connections should be inspected and repaired to solve the electrolysis problem. Which technician is correct?
  - a. Technician A only
  - b. Technician B only
  - c. Both Technicians A and B
  - d. Neither Technician A nor B

# COOLING SYSTEM OPERATION AND DIAGNOSIS

**OBJECTIVES:** After studying this chapter, the reader should be able to:

- Prepare for ASE Engine Repair (A1) certification test content area “D” (Lubrication and Cooling Systems Diagnosis and Repair).
- Describe how coolant flows through an engine.
- Discuss the operation of the thermostat.
- Explain the purpose and function of the radiator pressure cap.
- Describe the operation and service of water pumps.
- Discuss how to diagnose cooling system problems.

**KEY TERMS:** Bar • Bleed holes • Bypass • Centrifugal pump • Coolant recovery system • Cooling fins • Core tubes • Impeller • Parallel flow system • Reverse cooling • Scroll • Series flow system • Series-parallel flow system • Silicone coupling • Steam slits • Surge tank • Thermostatic spring

## COOLING SYSTEM

**PURPOSE AND FUNCTION** Satisfactory cooling system operation depends on the design and operating conditions of the system. The design is based on heat output of the engine, radiator size, type of coolant, size of water pump (coolant pump), type of fan, thermostat, and system pressure. The cooling system must allow the engine to warm up to the required operating temperature as rapidly as possible and then maintain that temperature.

Peak combustion temperatures in the engine run from 4,000°F to 6,000°F (2,200°C to 3,300°C). The combustion temperatures will average between 1,200°F and 1,700°F (650°C and 925°C). Continued temperatures as high as this would weaken engine parts, so heat must be removed from the engine. The cooling system keeps the head and cylinder walls at a temperature that is within the range for maximum efficiency. The cooling system removes about one-third of the heat created in the engine. Another third escapes to the exhaust system.

● SEE FIGURE 1.

**LOW-TEMPERATURE ENGINE PROBLEMS** Engine operating temperatures must be above a minimum temperature for proper engine operation. If the coolant temperature does not reach the specified temperature as determined by the thermostat, then the following engine-related faults can occur.

- A P0128 diagnostic trouble code (DTC) can be set. This code indicates “coolant temperature below thermostat regulating temperature,” which is usually caused by a defective thermostat staying open or partially open.

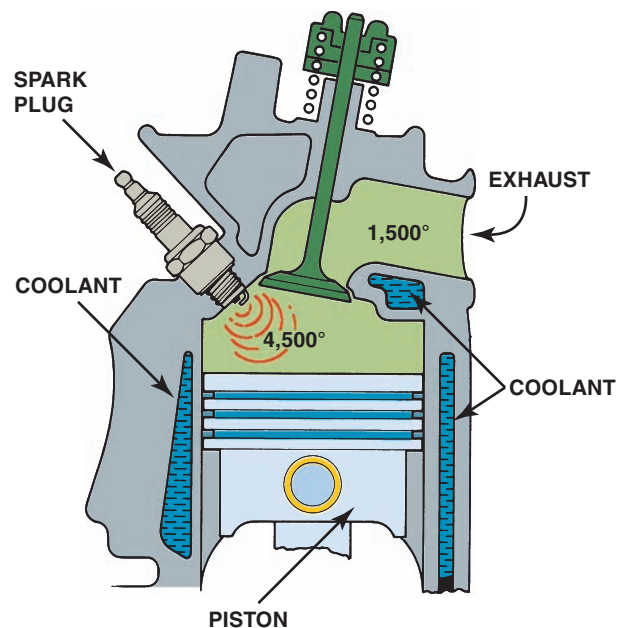

**FIGURE 1** Typical combustion and exhaust temperatures.

- Moisture created during the combustion process can condense and flow into the oil. For each gallon of fuel used, moisture equal to a gallon of water is produced. The condensed moisture combines with unburned hydrocarbons and additives to form carbonic acid, sulfuric acid, nitric acid, hydrobromic acid, and hydrochloric acid. To reduce cold engine problems and to help start engines in cold climates, most manufacturers offer block



## TECH TIP

**Overheating Can Be Expensive**

A faulty cooling system seems to be a major cause of engine failure. Engine rebuilders often have nightmares about seeing their rebuilt engine placed back in service in a vehicle with a clogged radiator. Most engine technicians routinely replace the water pump and all hoses after an engine overhaul or repair. The radiator should also be checked for leaks and proper flow whenever the engine is repaired or replaced. Overheating is one of the most common causes of engine failure.

heaters as an option. These block heaters are plugged into household current (110 volts AC) and the heating element warms the coolant.

**HIGH-TEMPERATURE ENGINE PROBLEMS** Maximum temperature limits are required to protect the engine. Higher than normal temperatures can cause the following engine-related issues.

- High temperatures will oxidize the engine oil producing hard carbon and varnish. The varnish will cause the hydraulic valve lifter plungers to stick. Higher than normal temperatures will also cause the oil to become thinner (lower viscosity than normal). Thinned oil will also get into the combustion chamber by going past the piston rings and through valve guides to cause excessive oil consumption.
- The combustion process is very sensitive to temperature. High coolant temperatures raise the combustion temperatures to a point that may cause detonation (also called spark knock or ping) to occur.

## COOLING SYSTEM OPERATION

**PURPOSE AND FUNCTION** Coolant flows through the engine, where it picks up heat. It then flows to the radiator, where the heat is given up to the outside air. The coolant continually recirculates through the cooling system, as illustrated in ● FIGURES 2 AND 3.

**COOLING SYSTEM OPERATION** The temperature of the coolant rises as much as 15°F (8°C) as it goes through the engine and cools as it goes through the radiator. *The coolant flow rate may be as high as 1 gallon (4 liters) per minute for each horsepower the engine produces.*

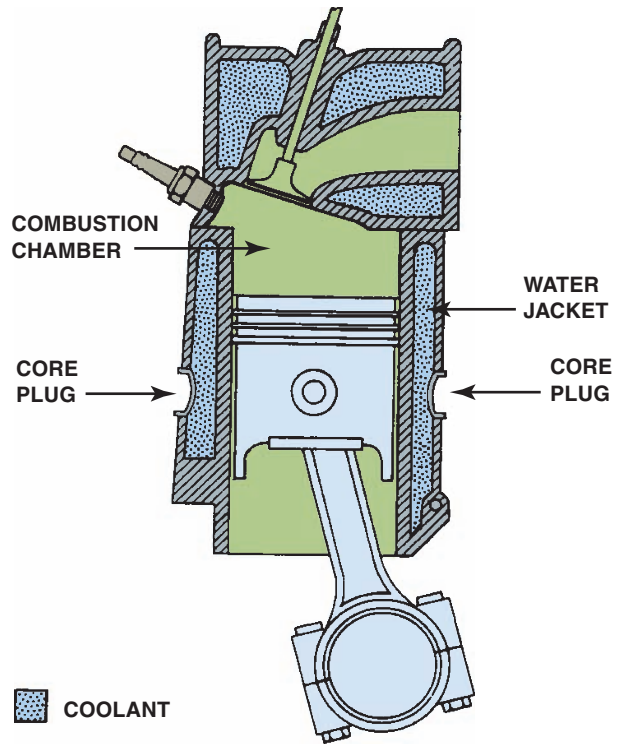

**FIGURE 2** Coolant circulates through the water jackets in the engine block and cylinder head.

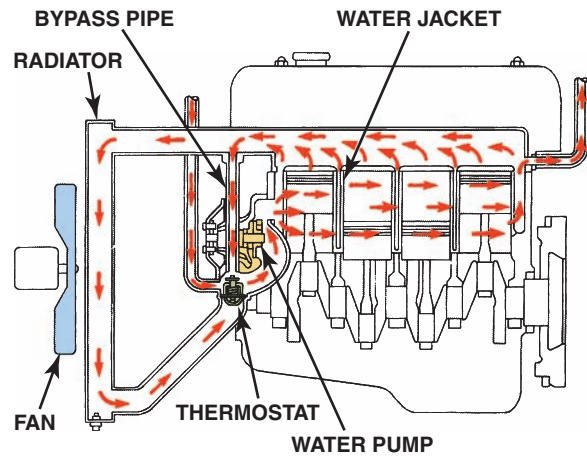

**FIGURE 3** Coolant flow through a typical engine cooling system.

Hot coolant comes out of the thermostat housing on the top of the engine on most engines. The engine coolant outlet is connected to the radiator by the upper radiator hose and clamps. The coolant in the radiator is cooled by air flowing through the radiator. As the coolant moves through the radiator, it cools. The cooler coolant leaves the radiator through an outlet and the lower radiator hose, and then flows to the inlet side of the water pump, where it is recirculated through the engine.

**NOTE:** Some newer engine designs such as Chrysler's 4.7 liter V-8 and General Motor's 4.8, 5.3, 5.7, and

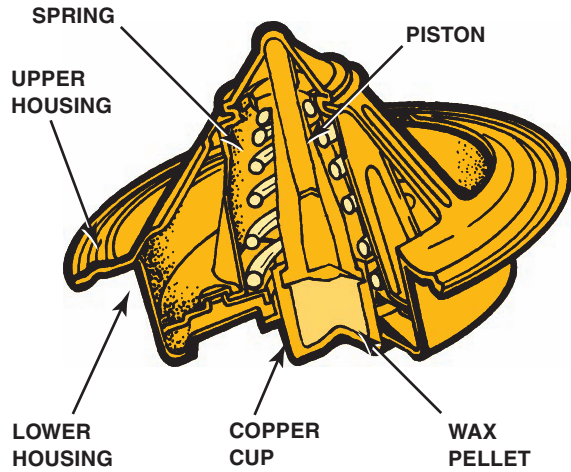

**FIGURE 4** A cross section of a typical wax-actuated thermostat showing the position of the wax pellet and spring.

6.0 liter V-8s place the thermostat on the inlet side of the water pump. As the cooled coolant hits the thermostat, the thermostat closes until the coolant temperature again causes it to open. Placing the thermostat in the inlet side of the water pump therefore reduces the rapid temperature changes that could cause stress in the engine, especially if aluminum heads are used with a cast iron block.

Radiators are designed for the maximum rate of heat transfer using minimum space. Cooling airflow through the radiator is aided by a belt- or electric motor-driven cooling fan.

## THERMOSTATS

**PURPOSE AND FUNCTION** There is a normal operating temperature range between low-temperature and high-temperature extremes. The thermostat controls the minimum normal temperature. The thermostat is a temperature-controlled valve placed at the engine coolant outlet on most engines.

**THERMOSTAT OPERATION** An encapsulated wax-based plastic pellet heat sensor is located on the engine side of the thermostatic valve. As the engine warms, heat swells the heat sensor. ● **SEE FIGURE 4.**

A mechanical link, connected to the heat sensor, opens the thermostat valve. As the thermostat begins to open, it allows some coolant to flow to the radiator, where it is cooled. The remaining part of the coolant continues to flow through the bypass, thereby bypassing the thermostat and flowing back through the engine. ● **SEE FIGURE 5.**

The rated temperature of the thermostat indicates the temperature at which the thermostat starts to open. The thermostat is fully open at about 20°F higher than its opening temperature. ● **SEE CHART 1.**

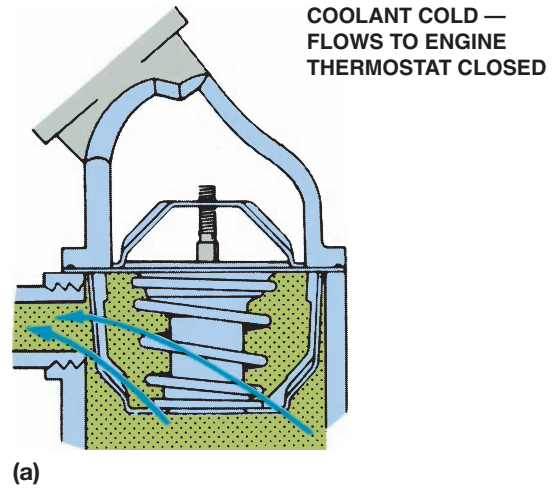

(a)

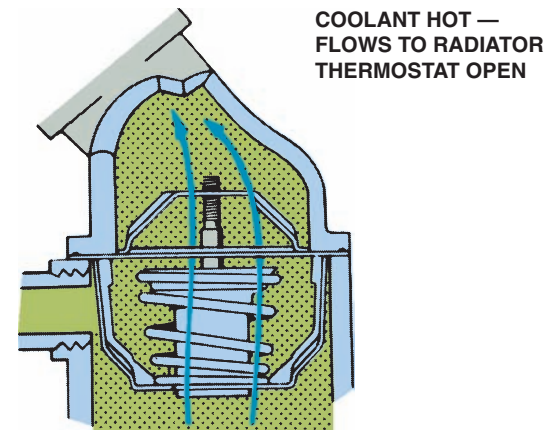

(b)

**FIGURE 5** (a) When the engine is cold, the coolant flows through the bypass. (b) When the thermostat opens, the coolant can flow to the radiator.

Thermostat Temperature Rating	Starts to Open	Fully Open
180°F	180°F	200°F
195°F	195°F	215°F

**CHART 1**

The temperature of the coolant depends on the rating of the thermostat.

If the radiator, water pump, and coolant passages are functioning correctly, the engine should always be operating within the opening and fully open temperature range of the thermostat. ● **SEE FIGURE 6.**

**NOTE:** A bypass around the closed thermostat allows a small part of the coolant to circulate within the engine during warm-up. It is a small passage that leads from



**FIGURE 6** A thermostat stuck in the open position caused the engine to operate too cold. If a thermostat is stuck closed, this can cause the engine to overheat.

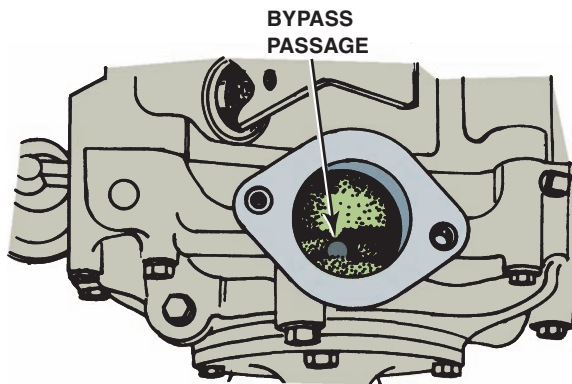

**FIGURE 7** This internal bypass passage in the thermostat housing directs cold coolant to the water pump.

**the engine side of the thermostat to the inlet side of the water pump. It allows some coolant to bypass the thermostat even when the thermostat is open. The bypass may be cast or drilled into the engine and pump parts.**

● SEE FIGURES 7 AND 8.

The bypass aids in uniform engine warm-up. Its operation eliminates hot spots and prevents the building of excessive coolant pressure in the engine when the thermostat is closed.

**THERMOSTAT TESTING** There are three basic methods used to check the operation of the thermostat.

1. **Hot water method.** If the thermostat is removed from the vehicle and is closed, insert a 0.015 in. (0.4 mm) feeler gauge in the opening so that the thermostat will hang on the feeler gauge. The thermostat should then be suspended by the feeler gauge in a container of water or coolant along with a thermometer. The container should be heated until the thermostat opens enough to release and

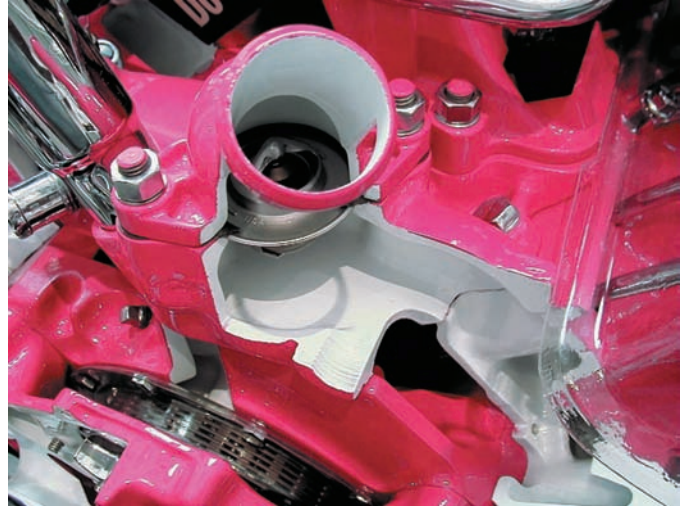

**FIGURE 8** A cutaway of a small block Chevrolet V-8 showing the passage from the cylinder head through the front of the intake manifold to the thermostat.



#### TECH TIP

##### **Do Not Take Out the Thermostat!**

Some vehicle owners and technicians remove the thermostat in the cooling system to “cure” an overheating problem. In some cases, removing the thermostat can cause overheating rather than stop it. This is true for three reasons.

1. Without a thermostat the coolant can flow more quickly through the radiator. The thermostat adds some restriction to the coolant flow, and therefore keeps the coolant in the radiator longer. This also allows additional time for the heat transfer between the hot engine parts and the coolant. The presence of the thermostat thus ensures a greater reduction in the coolant temperature before it returns to the engine.
2. Heat transfer is greater with a greater difference between the coolant temperature and air temperature. Therefore, when coolant flow rate is increased (no thermostat), the temperature difference is reduced.
3. Without the restriction of the thermostat, much of the coolant flow often bypasses the radiator entirely and returns directly to the engine.

If overheating is a problem, removing the thermostat will usually not solve the problem. Remember, the thermostat controls the temperature of the engine coolant by opening at a certain temperature and closing when the temperature falls below the minimum rated temperature of the thermostat.

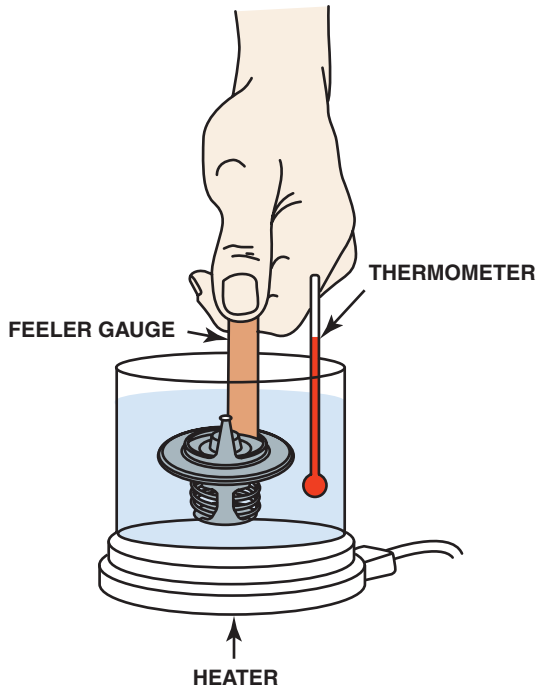

**FIGURE 9** Checking the opening temperature of a thermostat.

fall from the feeler gauge. The temperature at which the thermostat falls is the opening temperature of the thermostat. If it is within 5°F (4°C) of the temperature stamped on the thermostat, the thermostat is satisfactory for use. If the temperature difference is greater, the thermostat should be replaced. ● **SEE FIGURE 9.**

2. **Infrared thermometer method.** An infrared thermometer (also called a pyrometer) can be used to measure the temperature of the coolant near the thermostat. The area on the engine side of the thermostat should be at the highest temperature that exists in the engine. A properly operating cooling system should cause the pyrometer to read as follows:
  - As the engine warms, the temperature reaches near thermostat opening temperature.
  - As the thermostat opens, the temperature drops just as the thermostat opens, sending coolant to the radiator.
  - As the thermostat cycles, the temperature should range between the opening temperature of the thermostat and 20°F (11°C) above the opening temperature.

**NOTE:** If the temperature rises higher than 20°F (11°C) above the opening temperature of the thermostat, inspect the cooling system for a restriction or low coolant flow. A clogged radiator could also cause the excessive temperature rise.

3. **Scan tool method.** A scan tool can be used on many vehicles to read the actual temperature of the coolant as



**FIGURE 10** Some thermostats are an integral part of the housing. This thermostat and radiator hose housing is serviced as an assembly. Some thermostats snap into the engine radiator fill tube underneath the pressure cap.

detected by the engine coolant temperature (ECT) sensor. Although the sensor or the wiring to and from the sensor may be defective, at least the scan tool can indicate what the computer “thinks” is the engine coolant temperature.

**THERMOSTAT REPLACEMENT** Two important things about a thermostat include:

1. An overheating engine *may* result from a faulty thermostat.
2. An engine that does not get warm enough *always* indicates a faulty thermostat.

To replace the thermostat, coolant will have to be drained from the radiator drain petcock to lower the coolant level below the thermostat. It is not necessary to completely drain the system. The hose should be removed from the thermostat housing neck and then the housing removed to expose the thermostat. ● **SEE FIGURE 10.**

The gasket flanges of the engine and thermostat housing should be cleaned, and the gasket surface of the housing must be flat. The thermostat should be placed in the engine with the sensing pellet *toward* the engine. Make sure that the thermostat position is correct, and install the thermostat housing with a new gasket or O-ring.

**CAUTION:** Failure to set the thermostat into the recessed groove will cause the housing to become tilted when tightened. If this happens and the housing bolts are tightened, the housing will usually crack, creating a leak.

The upper hose should then be installed and the system refilled. Install the correct size of radiator hose clamp.